

10Gb/s SFP+ 850nm 300m Transceiver

TS8511A-CN Product Specification

FEATURES

- Typical data rate 1.25Gbps
- 1310nm FP Laser and PIN photo detector
- Duplex LC receptacle
- Single +3.3V power supply
- Hot-pluggable
- International Class1 laser safety certified
- Operating temperature range: 0 ~ +70°C
- RoHS Compliant
- Support Digital Diagnostic Monitoring interface
- Max reach 10km over SMF

APPLICATIONS

- 10 Gigabit Ethernet
- Servers, switches, storage and host card adapters
- High-performance computing clusters

ORDERING INFORMATION

Part Number	Form Factor	Data Rate	Media	Distance (km)	Wavelength (nm)	Temperature (°C)
TS8511A-CN	SFP+	10.3Gbps	MMF	0.3	850	0~70

ABSOLUTE MAXIMUM RATINGS

Exceeding the limits below may damage the transceiver permanently.

Parameter	Symbol	Min	Typ	Max	Unit.	Note
Storage Temperature	TSTG	-40	-	85	°C	
Operating Relative Humidity	RH	5	-	95	%	
Supply Voltage	VCC	-0.5	-	4	V	

RECOMMENDED OPERATING CONDITIONS

Parameter	Symbol	Min	Typ	Max	Unit.	Note
Operating Case Temperature	Tc	0	-	70	°C	
Supply Voltage	VCC3	3.13	3.3	3.47	V	
Supply Current	ICC3	-	-	300	mA	+3.3V Supply
Data Rate	DR	-	10.3125	-	Gbps	

ELECTRICAL and OPTICAL CHARACTERISTICS

Parameter	Symbol	Min	Typ	Max	Unit.	Note
Transmitter@10.3125Gbps						
Tx Differential Input Amplitude	Vin p-p	180	-	700	mV	
Input Differential Impedance	Zin	80	100	120	Ω	
Output Optical Power	PO	-5	-	-1	dBm	
Extinction Ratio	ER	3	-	-	dB	
Center Wavelength Range	λc	840	850	860	nm	
Spectral Width	σ	-	-	3.5	nm	
Optical Return Loss Tolerance	RL	12	-	-	dB	
Output Optical Eye	Compliant with G.957					
Tx Disable Voltage	VOH	2	-	VCC	V	LVTTTL
	VOL	0	-	0.4	V	LVTTTL
Optical Power at Tx Disable	Ptxdis	-	-	-30	dBm	
Receiver@10.3125Gbps						
Rx Differential Output Amplitude	Vout p-p	300	-	850	mV	
Receiver Optical Wavelength	λc	840	850	860	nm	
Receiver Sensitivity	Sen	-	-	-11.1	dBm	Note 1
Receiver Overload	OL	-1	-	-	dBm	
LOS Voltage	Normal	2	-	Vcc	V	LVTTTL
	Fault	0	-	0.4	V	LVTTTL

Parameter	Symbol	Min	Typ	Max	Unit.	Note
LOS Assert Level	LOSA	-26	-	-	dBm	
LOS De-Assert Level	LOSD	-	-	-13	dBm	
LOS Hysteresis	LOSH	0.5		6	dB	

Notes:

1.Measured with 2^31-1 NRZ Pattern. BER≤1E-12@10Gpbs, ER=3dB

Digital Diagnostic Functions

Parameter	Symbol	Min.	Max.	Unit	Repeatability	Notes
Temperature	DDML_Temp	-3	3	°C	± 1°C	1LSB=1/256°C
Supply Voltage	DDML_VCC	-3%	3%	V	± 1 %	1LSB=0.1mV
Bias Current	DDML_Ibias	-10%	10%	mA	± 5 %	1LSB=2uA
TX Optical Power	DDML_TX	-3	+3	dB	± 0.5 dB	1LSB=0.1uW
RX Optical Power	DDML_RX	-3	+3	dB	± 1.5 dB	1LSB=0.1uW

PIN DIAGRAM

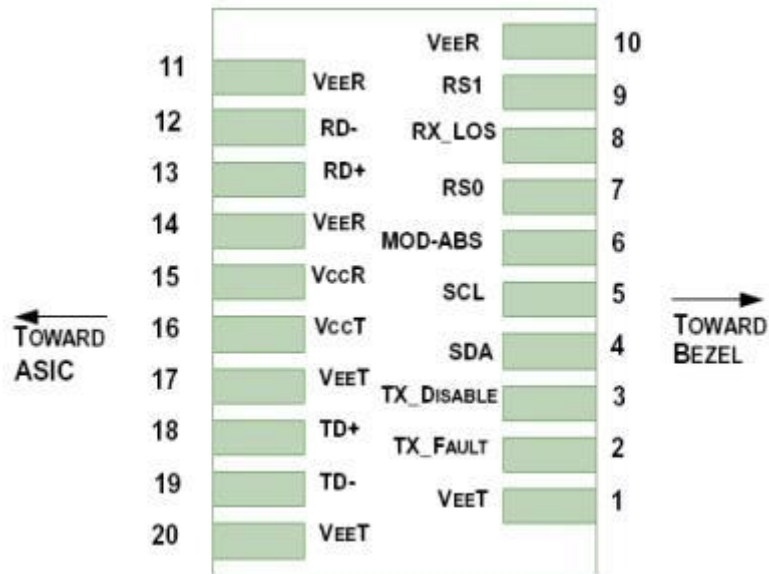

PIN DESCRIPTIONS

Pin	Symbol	Description	Notes
1	VEET	Module Transmitter Ground	1
2	TX_FAULT	Module Transmitter Fault	2
3	TX_DISABLE	Transmitter Disable; Turns off transmitter laser output	3
4	SDA	2-Wire Serial Interface Data Line (MOD-DEF2)	
5	SCL	2-Wire Serial Interface Clock (MOD-DEF1)	
6	MOD_ABS	Module Absent, connected to VEET or VEER in the module	2
7	RS0	Rate Select 0, NOT implement	4
8	RX_LOS	Receiver Loss of Signal Indication (in FC designated as RX_LOS, in SONET designated as LOS, and in Ethernet designated as NOT Signal Detect)	2
9	RS1	Rate Select 1, NOT implement	4
10	VEER	Module Receiver Ground	1
11	VEER	Module Receiver Ground	1
12	RD-	Receiver Inverted Data Output	
13	RD+	Receiver Non-Inverted Data Output	
14	VEER	Module Receiver Ground	1
15	VCCR	Module Receiver 3.3 V Supply	
16	VCCT	Module Transmitter 3.3 V Supply	
17	VEET	Module Transmitter Ground	1
18	TD+	Transmitter Non-Inverted Data Input	
19	TD-	Transmitter Inverted Data Input	
20	VEET	Module Transmitter Ground	1

Notes:

- 1.The module ground pins are isolated from the module case.
- 2.The pins shall be pulled up with 4.7K- 10Kohms to a voltage between 3.14V and 3.46V on host board.
- 3.The pin is pulled up to VCCT with a 4.7K- 10KΩ resistor in the module.
- 4.The pins are pulled low to VEET with a >30kΩ resistor in the module.

MECHANICAL SPECIFICATION

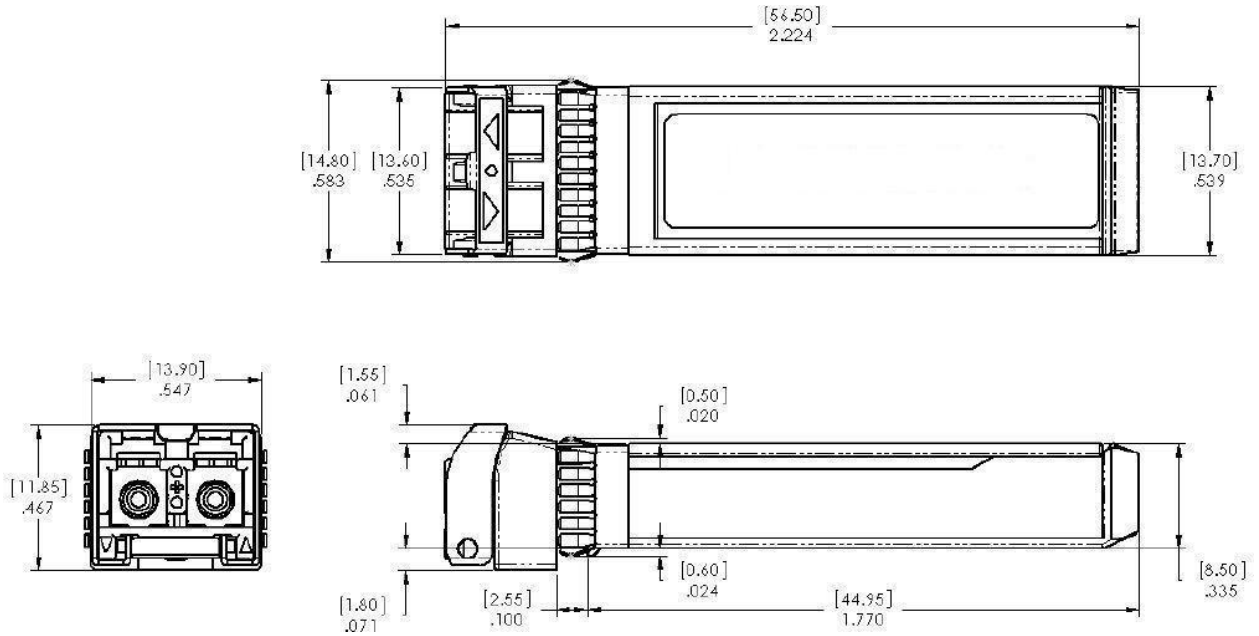

LABEL DIAGRAM

